

## RASTA-SMD-1722R(ROM base) Low-Power High-Performance and Low-Cost 65 Channel SMD GPS Module

Data Sheet  
Version 1.3

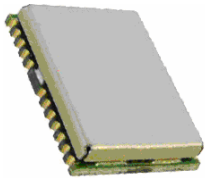

### Abstract

Technical data sheet describing the cost effective, high-performance RASTA-SMD-1722R based series of ultra high sensitive GPS modules.

The RASTA-SMD-1722R is a GPS module that is sensitive to *electrostatic dis- charge (ESD)*. Please handle with appropriate care.

The Acceptability of Electronic Assemblies of the RASTA-SMD-1722R has been under **IPC-A-610D** specification



## Version History

| Rev. | Date     | Description                             |
|------|----------|---|
| 1.1  | 10-12-08 | Initial Draft – preliminary information |
| 1.2  | 01-20-09 | Preliminary                             |
| 1.3  | 01-04-09 | Minor corrections                       |
|      |          |   |

### Order Information (SMD GPS modules, RASTA-SMD-1722R )

| Model Name                   | Dimension        | PIN            | Architecture |
|------------------------------|------------------|----------------|--------------|
| <b>RASTA-SMD-1722R-1513R</b> | <b>15mm*13mm</b> | <b>36 pins</b> | <b>ROM</b>   |
| RASTA-SMD-1722R-1612R        | 16mm*12.2mm      | 24 pins        | ROM          |
| RASTA-SMD-1722R-1618R        | 16mm*18mm        | 24 pins        | ROM          |
| <b>RASTA-SMD-1722R</b>       | <b>17mm*12mm</b> | <b>28 pins</b> | <b>ROM</b>   |
| RASTA-SMD-1722R-2525F        | 25mm*25mm        | 30 pins        | Flash        |
| RASTA-SMD-1722R-2525R        | 25mm*25mm        | 30 pins        | ROM          |

### Note

#### Flash version supports the features ;

- Binary code (Configuration command programmable)
- Selectable NMEA output data sentences
- Selectable Serial Port Settings. (4800/9600/38400/115200bps. Default : 9600)
- Selectable update rate (1 / 2 / 4 / 5 / 8 / 10 Hz update rate (ROM version only supports 1Hz default))
- Firmware upgrade

# 1 Functional Description

## 1.1 Introduction

The RASTA-SMD-1722R is a small form factor GPS module solution intended for a broad range of Original Equipment Manufacturer (OEM) products, where fast and easy system integration and minimal development risk is required.

The RASTA-SMD-1722R GPS receiver's -161dBm tracking sensitivity allows continuous position coverage in nearly all application environments. Its high performance search engine is capable of testing 8,000,000 time-frequency hypotheses per second, offering industry-leading signal acquisition and TTFF speed.

The receiver is optimized for applications requiring high performance, low power, and low cost; suitable for a wide range of OEM configurations including mobile phone, PND, asset tracking, and vehicle navigation products.

The very small 17mm x 22.4mm form factor and the SMT pads allow standard surface mount device pick-and-place process in fully automated assembly process; enabling high-volume, very cost-efficient production.

## 1.2 Features

- 65 Channel GPS L1 C/A Code
- Perform 8 million time-frequency hypothesis testing per second
- Open sky hot start 1 sec
- Open sky cold start 29 sec
- Signal detection better than -161dBm
- Multipath detection and suppression
- Accuracy 2.5m CEP
- Maximum update rate 10Hz
- Tracking current ~23mA
- Supports active and passive antenna

## 1.3 Applications

- Automotive and Marine Navigation
- Automotive Navigator Tracking
- Emergency Locator
- Geographic Surveying
- Personal Positioning
- Sporting and Recreation

## 2 Characteristics

### 2.1 General Specification

| Parameter          | Specification   |
|--------------------|---|
| Receiver Type      | 65 Channels<br>GPS L1 frequency, C/A Code   |
| Time-To-First-Fix  | Cold Start (Autonomous) 29s (Average, under open sky)<br>Warm Start (Autonomous) 28s (Average, under open sky)<br>Hot Start (Autonomous) 1s (Average, under open sky) |
| Sensitivity        | Tracking & Navigation -161 dBm<br>Reacquisition -158 dBm<br>Cold Start (Autonomous) -148 dBm  |
| Accuracy           | Autonomous 2.5 m CEP<br>Velocity 0.1 m/sec (without aid)<br>Time 300 ns   |
| Update Rate        | Supports 1 / 2 / 4 / 5 / 8 / 10 Hz update rate (1Hz default)  |
| Velocity Accuracy  | 0.1m/s  |
| Heading Accuracy   | 0.5 degrees   |
| Dynamics           | □ 4 G (39.2 m/sec)  |
| Operational Limits | Velocity 515 m/s (1000 knots)<br>Altitude <18000 meters<br>(COCOM limit, either may be exceeded but not both)   |
| Serial Interface   | 3.3V LVTTTL level   |
| Datum              | Default WGS-84<br>User definable  |
| Input Voltage      | 3.3V DC +/-10%  |
| Input Current      | ~23mA tracking  |
| Dimension          | 17mm L x 22mm W   |
| Weight             | 2g  |

**Table 1: RASTA-SMD-1722R general specification**

\*: GPGGA, GPGSA, GPGSV, GPRMC, GPVTG are default output message

## 2.2 Block Diagram

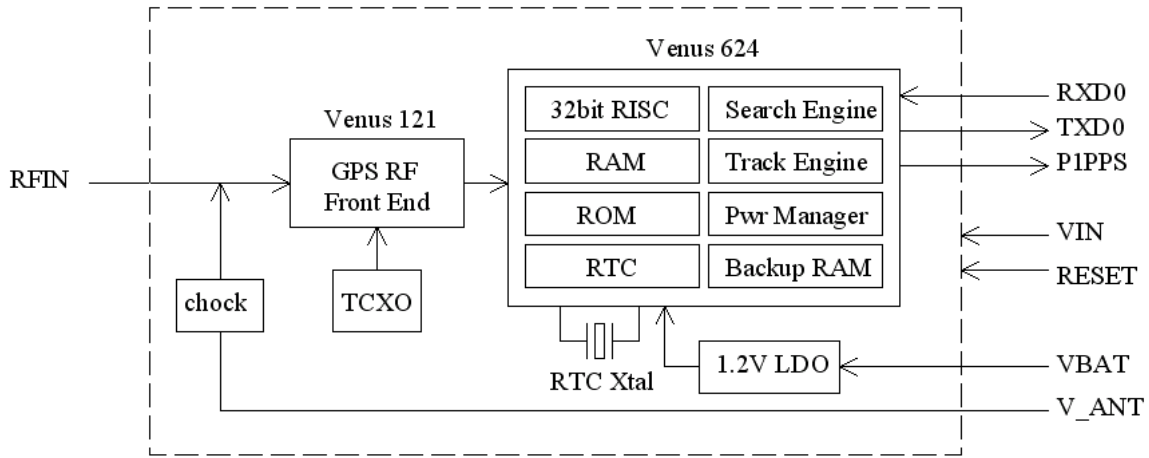

Figure 1: RASTA-SMD-1722R Hardware Block Schematic

## 2.2 Serial Port Settings

The default configuration within the standard GPS firmware is:

- Standard configuration of serial port:
- Supporting 4800/9600 baud rate (**Default Value : 9600**), 8 data bits, no parity, 1 stop bit, no flow control

## 2.3 Improved TTFF

In order to improve the TTFF (Time To First Fix), The system designer has to supply the power from the system to the Pin 11 V-bat to support the RTC with a back-up power when no system power is available.

## 2.4 Communication Specifications

| Item              | Description                  |
|-------------------|------------------------------|
| Interface         | Full duplex serial interface |
| Bit rate          | 4800/9600/38400/115200bps    |
| Start bit         | 1bit                         |
| Stop bit          | 1bit                         |
| Data bit          | 8bit                         |
| Parity            | None                         |
| Transmission data | SACII NMEA0183 Ver:3.01      |
| Update rate       | 1Hz                          |
| Output sentence   | GGA/GSA/GSV/RMC/VTG (typ)    |

Table 2: Communication specifications

## 2.5 Multi-path Mitigation

Multipath refers to the existence of signals reflected from objects in the vicinity of a receiver's antenna that corrupt the direct line-of-sight signals from the GPS satellites, thus degrading the accuracy of both code-based and carrier phase-based measurements. Particularly difficult is close-in multipath in which the reflected secondary signals arrive only slightly later (within about 100 nanoseconds) than does the direct-path signal, having been reflected from objects only a short distance from the receiver antenna.

RASTA-SMD-1722R deploys the advanced multi-path detection and suppression algorithm to reduce multipath errors, the GPS signals themselves can be designed to provide inherent resistance to multipath errors

## 2.6 Operating Conditions

| Description                       | Min  | Typical | Max  |
|-----------------------------------|------|---------|------|
| V <sub>CC</sub>                   | 2.7v | 3.3v    | 3.6v |
| Enhanced-mode Acquisition Current |      | 70 mA   |      |
| Low power Acquisition Current     |      | 50mA    |      |
| Tracking Current                  |      | 23mA    |      |

Table 3: Operating Conditions

## 2.7 Absolute Maximum Ratings

| Parameter                       | Min  | Max                  | Units | Remark |
|---------------------------------|------|----------------------|-------|--------|
| Power supply voltage (VCC)      | -0.5 | 3.6                  | V     |        |
|                                 |      |                      |       |        |
| Backup battery voltage (V_BCKP) | -0.5 | 3.6                  | V     |        |
| Input pin voltage               | -0.5 | V <sub>CC</sub> +0.5 | V     |        |

Table 4: Absolute Maximum Ratings

## 2.8 Antenna

A numbers of important properties of GNSS antennas affect functionality and performance, including;

- Frequency coverage
- Gain pattern
- Circular polarization
- Multipath suppression
- Phase Center
- Impact on receiver sensitivity
- Interference handling

The RASTA-SMD-1722R module is designed to work both active and passive antenna. Active antenna with gain in range of 10 ~ 30dB and noise figure less than 2dB can be used.

### 3. Mechanical Characteristics

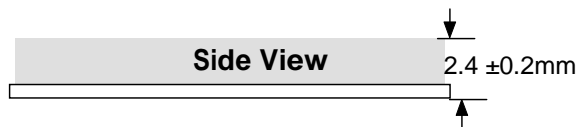
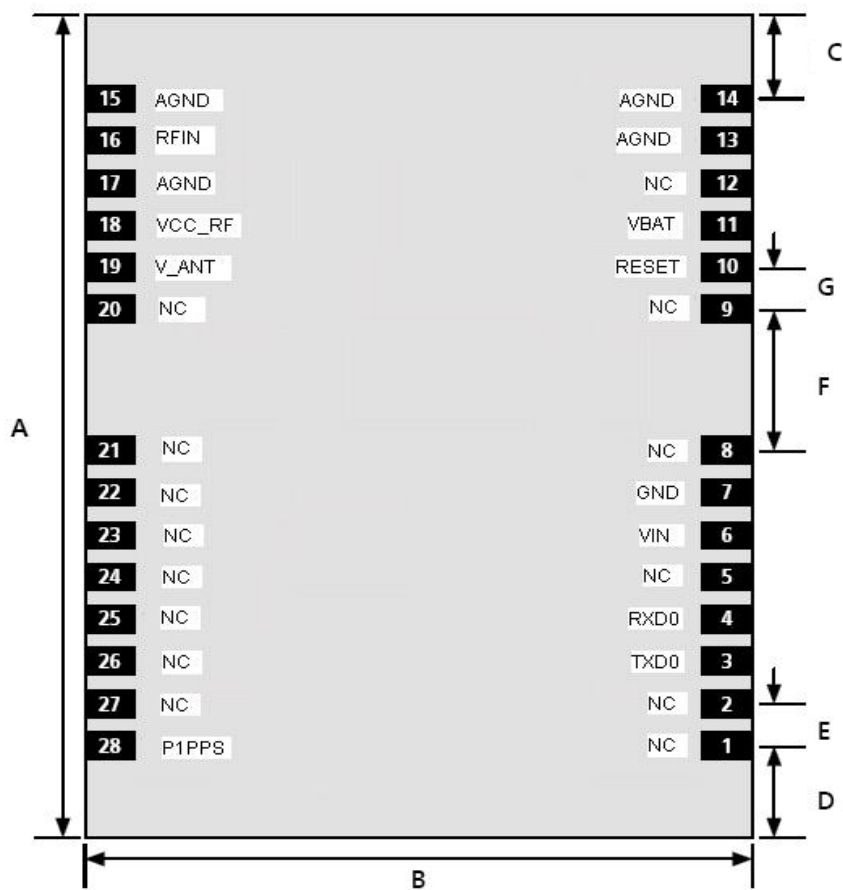

|   |        |
|---|--------|
| A | 22.4mm |
| B | 17.0mm |
| C | 2.85mm |
| D | 2.55mm |
| E | 1.1mm  |
| F | 3.8mm  |
| G | 1.1mm  |



### 3.1. PINOUT DESCRIPTION

| Pin No. | Name   | Description   |
|---------|--------|---|
| 1       | NC     | No connection   |
| 2       | NC     | No conneciton   |
| 3       | TXD0   | UART output, 3.3V LVTTTL  |
| 4       | RXD0   | UART input, 3.3V LVTTTL   |
| 5       | NC     | No connection   |
| 6       | VIN    | Main 3.3V supply input  |
| 7       | GND    | System ground   |
| 8       | NC     | No connection   |
| 9       | NC     | No connection   |
| 10      | RESET  | External active-low reset input.<br>Only needed when power supply rise time is very slow. |
| 11      | VBAT   | Backup supply voltage for RTC and backup memory, minimum 1.5V                             |
| 12      | NC     | No connection   |
| 13      | AGND   | RF ground   |
| 14      | AGND   | RF ground   |
| 15      | AGND   | RF ground   |
| 16      | RFIN   | GPS RF input, connect to antenna  |
| 17      | AGND   | RF ground   |
| 18      | VCC RF | RF section output voltage   |
| 19      | V ANT  | Antenna bias voltage input  |
| 20      | NC     | No connection   |
| 21      | NC     | No connection   |
| 22      | NC     | No connection   |
| 23      | NC     | No connection   |
| 24      | NC     | No connection   |
| 25      | NC     | No connection   |
| 26      | NC     | No connection   |
| 27      | NC     | No connection   |
| 28      | 1PPS   | 1 pulse per second time mark  |

Table 5: Pin definition

#### 4. Environmental Conditions

| Parameter   |           | Specification                        |
|-------------|-----------|--------------------------------------|
| Temperature | Operating | -40°C~+85°C                          |
|             | Storage   | -55°C~+100°C                         |
| Humidity    |           | 5%~95%                               |
| Storage     |           | 6 months in original vacuum package. |

Table 6: Environmental conditions

## 5. NMEA protocol

The serial interface protocol is based on the National Marine Electronics Association's NMEA 0183 ASCII interface specification. This standard is fully define in "NMEA 0183, Version 3.01" The standard may be obtained from NMEA, [www.nmea.org](http://www.nmea.org)

### 5.1 GGA-GLOBAL POSITIONING SYSTEM FIX DATA

Time, position and fix related data for a GPS receiver.

#### Structure:

```
$GPGGA,hhmmss.sss,ddmm.mmmm,a,dddmm.mmmm,a,x,xx,x.x,x.x,M,x.x,M,x.x,xxxx*hh<CR><LF>
```

1            2            3            4            5    6    7    8    9            10    11    12    13

#### Example:

```
$GPGGA,060932.448,2447.0959,N,12100.5204,E,1,08,1.1,108.7,M,,,,0000*0E<CR><LF>
```

| Field | Name             | Example    | Description   |
|-------|------------------|------------|---|
| 1     | UTC Time         | 060932.448 | UTC of position in hhmmss.sss format, (000000.00 ~ 235959.99)   |
| 2     | Latitude         | 2447.0959  | Latitude in ddmm.mmmm format<br>Leading zeros transmitted   |
| 3     | N/S Indicator    | N          | Latitude hemisphere indicator, 'N' = North, 'S' = South   |
| 4     | Longitude        | 12100.5204 | Longitude in dddmm.mmmm format<br>Leading zeros transmitted   |
| 5     | E/W Indicator    | E          | Longitude hemisphere indicator, 'E' = East, 'W' = West  |
| 6     | GPS indicator    | 1          | GPS quality indicator<br>0: position fix unavailable<br>1: valid position fix, SPS mode<br>2: valid position fix, differential GPS mode<br>3: GPS PPS Mode, fix valid<br>4: Real Time Kinematic. System used in RTK mode with fixed integers<br>5: Float RTK. Satellite system used in RTK mode. Floating integers<br>6: Estimated (dead reckoning) Mode<br>7: Manual Input Mode<br>8: Simulator Mode |
| 7     | Satellites Used  | 08         | Number of satellites in use, (00 ~ 12)  |
| 8     | HDOP             | 1.1        | Horizontal dilution of precision, (00.0 ~ 99.9)   |
| 9     | Altitude         | 108.7      | mean sea level (geoid), (-9999.9 ~ 17999.9)   |
| 10    | Geoid Separation |            | Geoid separation in meters according to WGS-84 ellipsoid (-999.9 ~ 9999.9)  |

|    |                 |      |  |
|----|-----------------|------|--|
| 11 | DGPS Age        |      | Age of DGPS data since last valid RTCM transmission in xxx format (seconds)<br>NULL when DGPS not used |
| 12 | DGPS Station ID | 0000 | Differential reference station ID, 0000 ~ 1023<br>NULL when DGPS not used                              |
| 13 | Checksum        | 0E   |  |

**Note:** The checksum field starts with a '\*' and consists of 2 characters representing a hex number. The checksum is the exclusive OR of all characters between '\$' and '\*'.

## 5.2 GLL - LATITUDE AND LONGITUDE, WITH TIME OF POSITION FIX AND STATUS

Latitude and longitude of current position, time, and status.

### Structure:

\$GPGLL,ddmm.mmmm,a,dddmm.mmmm,a,hmmss.sss,A,a\*hh<CR><LF>

1 2 3 4 5 6 7 8

### Example:

\$GPGLL,4250.5589,S,14718.5084,E,092204.999,A,A\*2D<CR><LF>

| Field | Name           | Example    | Description  |
|-------|----------------|------------|--|
| 1     | Latitude       | 4250.5589  | Latitude in ddmm.mmmm format<br>Leading zeros transmitted  |
| 2     | N/S Indicator  | S          | Latitude hemisphere indicator<br>'N' = North<br>'S' = South  |
| 3     | Longitude      | 14718.5084 | Longitude in dddmm.mmmm format<br>Leading zeros transmitted  |
| 4     | E/W Indicator  | E          | Longitude hemisphere indicator<br>'E' = East<br>'W' = West   |
| 5     | UTC Time       | 092204.999 | UTC time in hhmmss.sss format (000000.00 ~ 235959.99)  |
| 6     | Status         | A          | Status, 'A' = Data valid, 'V' = Data not valid   |
| 7     | Mode Indicator | A          | Mode indicator<br>'N' = Data not valid<br>'A' = Autonomous mode<br>'D' = Differential mode<br>'E' = Estimated (dead reckoning) mode<br>'M' = Manual input mode<br>'S' = Simulator mode |
| 8     | Checksum       | 2D         |  |

### 5.3 GSA - GPS DOP AND ACTIVE SATELLITES

GPS receiver operating mode, satellites used in the navigation solution reported by the GGA or GNS sentence and DOP values.

**Structure:**

```
$GPGSA,A,x,xx,xx,xx,xx,xx,xx,xx,xx,xx,xx,xx,xx,x.x,x.x,x.x*hh<CR><LF>
    1 2 3 3 3 3 3 3 3 3 3 3 3 3 4 5 6 7
```

**Example:**

```
$GPGSA,A,3,01,20,19,13,,,,,,40.4,24.4,32.2*0A<CR><LF>
```

| Field | Name                | Example                  | Description  |
|-------|---------------------|--------------------------|--|
| 1     | Mode                | A                        | Mode<br>'M' = Manual, forced to operate in 2D or 3D mode<br>'A' = Automatic, allowed to automatically switch 2D/3D |
| 2     | Mode                | 3                        | Fix type<br>1 = Fix not available<br>2 = 2D<br>3 = 3D  |
| 3     | Satellite used 1~12 | 01,20,19,13,,,,,<br>,,,, | Satellite ID number, 01 to 32, of satellite used in solution, up to 12 transmitted                                 |
| 4     | PDOP                | 40.4                     | Position dilution of precision (00.0 to 99.9)  |
| 5     | HDOP                | 24.4                     | Horizontal dilution of precision (00.0 to 99.9)  |
| 6     | VDOP                | 32.2                     | Vertical dilution of precision (00.0 to 99.9)  |
| 7     | Checksum            | 0A                       |  |

### 5.4 GSV - GPS SATELLITE IN VIEW

Numbers of satellites in view, PRN number, elevation angle, azimuth angle, and C/No. Four satellites details are transmitted per message. Additional satellite in view information is send in subsequent GSV messages.

**Structure:**

```
$GPGSV,x,x,xx,xx,xx,xxx,xx,...,xx,xx,xxx,xx *hh<CR><LF>
  1 2 3 4 5 6 7 4 5 6 7 8
```

**Example:**

```
$GPGSV,3,1,09,28,81,225,41,24,66,323,44,20,48,066,43,17,45,336,41*78<CR><LF>
$GPGSV,3,2,09,07,36,321,45,04,36,257,39,11,20,050,41,08,18,208,43*77<CR><LF>
```

| Field | NaME               | Example | Description  |
|-------|--------------------|---------|--|
| 1     | Number of message  | 3       | Total number of GSV messages to be transmitted (1-3)           |
| 2     | Sequence number    | 1       | Sequence number of current GSV message                         |
| 3     | Satellites in view | 09      | Total number of satellites in view (00 ~ 12)                   |
| 4     | Satellite ID       | 28      | Satellite ID number, GPS: 01 ~ 32, SBAS: 33 ~ 64 (33 = PRN120) |
| 5     | Elevation          | 81      | Satellite elevation in degrees, (00 ~ 90)                      |
| 6     | Azimuth            | 225     | Satellite azimuth angle in degrees, (000 ~ 359 )               |
| 7     | SNR                | 41      | C/No in dB (00 ~ 99)<br>Null when not tracking                 |
| 8     | Checksum           | 78      |  |

### 5.5 RMC - RECOMMENDED MINIMUM SPECIFIC GPS/TRANSIT DATA

Time, date, position, course and speed data provided by a GNSS navigation receiver.

**Structure:**

\$GPRMC,hhmmss.sss,A,dddmm.mmmm,a,dddmm.mmmm,a,x.x,x.x,ddmmyy,x.x,a,\*hh<CR><LF>

1            2            3            4            5            6 7        8            9 10 11 12    13

**Example:**

\$GPRMC,092204.999,A,4250.5589,S,14718.5084,E,0.00,89.68,211200,,A\*25<CR><LF>

| Field | NaME               | Example    | Description  |
|-------|--------------------|------------|--|
| 1     | UTC time           | 092204.999 | UTC time in hhmmss.sss format (000000.00 ~ 235959.999)   |
| 2     | Status             | A          | Status<br>'V' = Navigation receiver warning<br>'A' = Data Valid  |
| 3     | Latitude           | 4250.5589  | Latitude in dddmm.mmmm format<br>Leading zeros transmitted   |
| 4     | N/S indicator      | S          | Latitude hemisphere indicator<br>'N' = North<br>'S' = South  |
| 5     | Longitude          | 14718.5084 | Longitude in dddmm.mmmm format<br>Leading zeros transmitted  |
| 6     | E/W Indicator      | E          | Longitude hemisphere indicator<br>'E' = East<br>'W' = West   |
| 7     | Speed over ground  | 000.0      | Speed over ground in knots (000.0 ~ 999.9)   |
| 8     | Course over ground | 000.0      | Course over ground in degrees (000.0 ~ 359.9)  |
| 9     | UTC Date           | 211200     | UTC date of position fix, ddmmyy format  |
| 10    | Magnetic variation |            | Magnetic variation in degrees (000.0 ~ 180.0)  |
| 11    | Magnetic Variation |            | Magnetic variation direction<br>'E' = East<br>'W' = West   |
| 12    | Mode indicator     | A          | Mode indicator<br>'N' = Data not valid<br>'A' = Autonomous mode<br>'D' = Differential mode<br>'E' = Estimated (dead reckoning) mode<br>'M' = Manual input mode<br>'S' = Simulator mode |
| 13    | checksum           | 25         |  |



## 5.6 VTG - COURSE OVER GROUND AND GROUND SPEED

The Actual course and speed relative to the ground.

### Structure:

GPVTG,x.x,T,x.x,M,x.x,N,x.x,K,a\*hh<CR><LF>

1 2 3 4 5 6

### Example:

\$GPVTG,89.68,T,,M,0.00,N,0.0,K,A\*5F<CR><LF>

| Field | Name     | Example | Description   |
|-------|----------|---------|---|
| 1     | Course   | 89.68   | True course over ground in degrees (000.0 ~ 359.9)  |
| 2     | Course   |         | Magnetic course over ground in degrees (000.0 ~ 359.9)  |
| 3     | Speed    | 0.00    | Speed over ground in knots (000.0 ~ 999.9)  |
| 4     | Speed    | 0.00    | Speed over ground in kilometers per hour (0000.0 ~ 1800.0)  |
| 5     | Mode     | A       | Mode indicator<br>'N' = not valid<br>'A' = Autonomous mode<br>'D' = Differential mode<br>'E' = Estimated (dead reckoning) mode<br>'M' = Manual input mode<br>'S' = Simulator mode |
| 6     | Checksum | 5F      |   |

## 5.7 ZDA- TIME AND DATE

### Structure:

\$GPRMC,hhmmss.sss,dd,mm.yyyy, , ,xxx<CR><LF>

1 2 3 4 5 6 7

### Example:

\$GPZDA,104548.04,25,03,2004,,\*6C<CR><LF>

| Field | Name            | Example   | Description   |
|-------|-----------------|-----------|---|
| 1     | UTC time        | 104548.04 | UTC time in hhmmss.ss format, 000000.00 ~ 235959.99           |
| 2     | UTC time: day   | 25        | UTC time day (01 ... 31)                                      |
| 3     | UTC time: month | 03        | UTC time: month (01 ... 12)                                   |
| 4     | UTC time: year  | 2004      | UTC time: year (4 digit year)                                 |
| 5     |                 |           | Local zone hour<br>Not being output by the receiver (NULL)    |
| 6     |                 |           | Local zone minutes<br>Not being output by the receiver (NULL) |
| 7     | 6C              | 6C        | Checksum  |

## Contact Information

We hope this datasheet will be helpful to the user to get the most out of the GPS module, furthermore feedback inputs about errors or mistakable verbalizations and comments or proposals to **I2R LABS** for further improvements are highly appreciated.

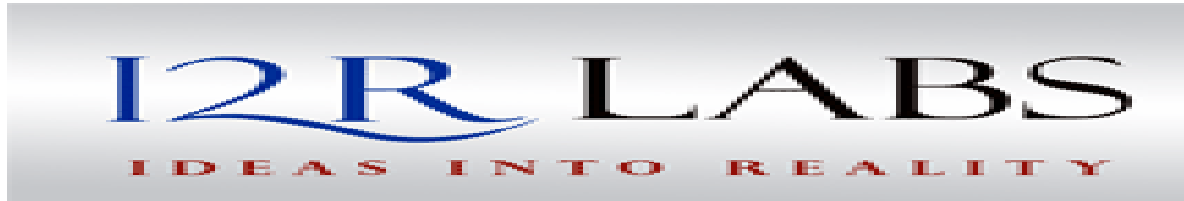

*Regd. Office: Sree Shruthilayam; No: 39,2 nd floor, Door No2, Near Apoorva Apartments, DB Sandra, Bangalore-560097;India,  
Ph +919740848961; Fax: +91-80-41503028, E-mail: [info@i2rlabs.com](mailto:info@i2rlabs.com) , web: [www.i2rlabs.com](http://www.i2rlabs.com)*

© 2009 I2R LABS. All rights reserved.

Not to be reproduced in whole or part for any purpose without written permission of **I2R LABS** ("**I2R LABS**") Information provided by **I2R LABS** is believed to be accurate and reliable. These materials are provided by **I2R LABS** as a service to its customers and may be used for informational purposes only. **I2R LABS** assumes no responsibility for errors or omissions in these materials, nor for its use **I2R LABS** reserves the right to change specification at any time without notice.

These materials are provides "as is" without warranty of any kind, either expressed or implied, relating to sale and/or use of **I2R LABS** products including liability or warranties relating to fitness for a particular purpose, consequential or incidental damages, merchantability, or infringement of any patent, copyright or other intellectual property right. **I2R LABS** further does not warrant the accuracy or completeness of the information, text, graphics or other items contained within these materials. **I2R LABS** shall not be liable for any special, indirect, incidental, or consequential damages, including without limitation, lost revenues or lost profits, which may result from the use of these materials.

**I2R LABS** products are not intended for use in medical, life-support devices, or applications involving potential risk of death, personal injury, or severe property damage in case of failure of the product.